

X8



627 - 631 VT-DRIVE



McCORMICK **DIGITAL SOLUTIONS** BRING THE FUTURE TO THE FIELD

Technological innovation improves working conditions, increases productivity and protects the environment. Following this philosophy, the Argo Tractors Group has prepared its tractors for the most cutting-edge digital and telematic technologies. This will help farmers manage their machinery fleets and their farms more efficiently and remotely, wherever they are. McCormick Digital Solutions offers a range of advanced functionalities:

- › **Telemetry and Remote Diagnostics:** Thanks to the Fleet & Remote Diagnostics Management system, telemetry monitors your fleet analysing tractor performance data, while remote diagnostics enables tractor parameters to be monitored and managed from a remote location.
- › **Precision Farming:** The Precision Steering Management satellite guidance system improves working accuracy and efficiency; the ISOBUS system allows optimum control of AEF-certified compatible implements.
- › **Farm Management:** McCormick Farm manages prescription maps and simplifies farm management.
- › **Digital Services:** The My McCormick app provides easy access to the McCormick world.
- › **Cloud Data:** The Agrirouter cloud platform allows integrated communication among all services.

McCormick Digital Solutions give you more performance, more efficiency and more profitability while improving simplicity, safety and comfort.



McCORMICK X8, TECHNOLOGY AT FULL THROTTLE

Technological innovation, constant pursuit of quality, sustainability, close attention to farmers' needs: these are the values that drive our business and have marked the history of the Argo Tractors Group since its inception. This ongoing commitment has led our engineers to develop the new McCormick **X8**, a tractor range that is designed to meet the most demanding needs of large farms and full-time agricultural contractors and sets the benchmark worldwide for technology, power, reliability and comfort.

The new Clever Cab of the **X8** exhibits a contemporary and aggressive look that will not go unnoticed. The cab interior offers a spacious working environment with automotive-grade fit and finish, ergonomically-arranged controls and easy-to-use instruments for superior operator comfort. The main strong points of the Clever Cab are:

- › Swivel seat with air suspension system, backrest heating and ventilation and tilt-adjustable headrest for enhanced operator vision. The armrest moves together with the seat for maximum comfort of operation.
- › Electronically controlled steering system for greater comfort and increased productivity.
- › High-grade sound insulation system: only 68 dB.
- › 12-inch touch screen display.

- › Powerful Alpine touch screen radio with DAB+, Android Auto, Apple CarPlay, Bluetooth, integrated microphone and USB ports.
- › Enhanced visibility: +14% glass area.
- › 210-degree windscreen wiper.
- › Large rear-view mirrors.
- › Twenty fully redesigned, high-mounted adjustable full LED work lights for maximum visibility when operating front implements.

The **X8** is powered by a new Stage V FPT NEF 67 engine that delivers up to 313 hp. The new engine is located within a rugged chassis with silent block rubber mounts which moves the tractor's centre of gravity forward. This results in a 59/41 front-to-rear weight distribution, improving the vehicle's overall balance and stability. This solution reduces vibrations to a minimum and enables the tractor to transfer all the power to the ground.

The **X8** range further features an innovative VT-Drive four-stage continuously variable transmission and a high-flow hydraulic system that provides a total flow of 212 l/min and supplies up to 160 l/min to eleven electrohydraulic remote valves.

Choosing McCormick means you can count on a reliable partner that delivers industry-leading technology along with outstanding performance and uncompromising reliability.

HIGHLIGHTS

Cab

- › New Clever Cab: four-post design with semi-active suspension system.
- › New layout: more room in every direction and maximum ergonomic comfort.
- › Heated and ventilated swivel seat with new active dynamic air suspension. Tilt-adjustable headrest and armrest integral with seat for enhanced operating comfort.
- › Data Screen Manager 12-inch touch screen monitor.
- › Automatic climate control.
- › 20 adjustable full LED work lights for full all-round visibility.
- › Transparent roof hatch with tinted glass for improved visibility and durability.

Engine

- › eVGT electronically controlled variable-geometry turbocharger.
- › HI-eSCR2 technology meeting Stage V emissions regulations.

- › Engine located within a rugged chassis to reduce vibrations and improve traction.
- › 550 l fuel tank, 70 l AdBlue tank.
- › Coolers opening from a single latch to allow easier and faster cleaning.

Transmission

- › VT-Drive four-stage continuously variable transmission.
- › Four programmable speed ranges.
- › Transmission controls integrated into the EasyPilot proportional controller.
- › Speed: up to 50 km/h at 1580 rpm.
- › Fuel economy and reduced operating costs.

Axles

- › Electronically controlled suspended front axle with wet multi-disc brakes.
- › Rear axle with annular wet multi-disc brakes.
- › Automatic 4WD and differential lock engagement.

- › Full locking differential for maximum tractive performance.
- › Tyre size up to 900/60 R42 (Ø 2.15 m).

Hydraulic system

- › Closed-centre hydraulic system with variable-displacement pump delivering up to 212 l/min.
- › Electronically controlled three-speed rear PTO.
- › Electronically controlled rear hitch with up to 12000 kg lifting capacity.

Onboard technology

- › ISOBUS and Precision Steering Management systems for increased efficiency and productivity.
- › Landini Fleet & Remote Diagnostics Management and Farm Management for efficient fleet and farm management.



HYDRAULIC SYSTEM

Configurability – Productivity.
page 38

ENGINE

Power – Efficiency – Sustainability
page 22

DIGITAL SOLUTIONS

Fleet - Diagnostics - Farm Management.
page 44

CAB

Visibility – Spaciousness
Innovation
page 8

ONBOARD TECHNOLOGY

PSM – ISOBUS – EazySteer – EazyGrip
page 46

TRACTION

Force – Comfort – Safety
page 34

TRANSMISSION

Responsiveness – Versatility
page 28



SEATED IN THE **CLEVER CAB**, YOU WORK IN COMPLETE COMFORT

After a long day's work, you feel less fatigued.

The engine is located within a rugged chassis and mounted on silent blocks to minimise shocks and vibrations. The cab with semi-active suspension can be specified with three different shock absorbing levels. The Clever Cab features a flat-deck platform and a ventilated air-suspension swivel seat with adjustable headrest and integral armrest for maximum comfort of operation. The automatic climate control ensures uniform airflow distribution in all directions for superior operator comfort.

Inside the Clever Cab, you always have everything under control.

With 14 percent more glass area, the new four-post cab of the X8 provides superb, unobstructed vision in all directions. The interior is more spacious than ever before and the controls are ergonomically designed according to anthropometric principles, servo assisted and user-friendly. The low round fenders further improve visibility to the sides of the vehicle. The 12-inch tablet-like touch screen monitor allows for simple and intuitive operation. Twenty adjustable full LED work lights provide full all-round visibility, while up to two relocatable rearview cameras allow the driver to monitor blind spots from the cab, making for improved safety and easy implement attachment.

Digital Solutions: improving performance has never been easier.

McCormick Digital Solutions provide a range of advanced solutions to help you manage more efficiently your fleet and your farm from remote locations. The Fleet & Remote Diagnostics Management monitors your tractor fleet analysing the vehicles performance data and enables remote control of tractor parameters. McCormick Farm manages prescription maps and simplifies farm management. Digital Solutions give you more efficiency, better performance and greater profitability while improving simplicity, safety and comfort.



HIGHLIGHTS

- › Clever Cab: bold lines, four-post design, +14% glass area.
- › Electrohydraulic semi-active cab suspension.
- › FOPS certified roof for protection against falling objects.
- › Four wide, well-spaced access steps integrated into the fuel tank.
- › Spacious interior and ergonomic design.
- › Automotive-style fit and finish with soft-touch materials.
- › Various storage compartments.
- › Instrument panel and steering column electrically adjustable in tilt and depth.
- › Ventilated air-suspension swivel seat with adjustable headrest and integral armrest for maximum comfort of operation.
- › Hide-away buddy seat for easier access to the cab.
- › Multifunction armrest with ergonomically-designed controller and integrated controls.
- › 12-inch DSM touch screen monitor with new functions.
- › Powerful Alpine radio with DAB+, MP3 player, Bluetooth, microphone, Android Auto and Apple CarPlay.
- › Four high-quality 200 W RMS Alpine speakers.
- › Efficient climate control for uniform airflow distribution in all directions.
- › Opening transparent roof hatch with sunshade.
- › Central windscreen wiper with 210-degree wipe angle to clean a larger area.
- › Heated extra-large square rearview mirrors.
- › Heated and tinted rear window with up to 75-degree opening angle.
- › Exhaust gas aftertreatment system integrated into the cab post for maximum visibility.
- › 20 latest-generation full LED work lights on cab, bonnet and fenders.



CLEVER CAB: YOUR NEW OFFICE IN FIRST CLASS

Our new **Clever Cab** welcomes you on board of McCormick high-power tractors. Beautiful, spacious, quiet and functional, the **Clever Cab** offers a working environment where every detail is cared for with the highest level of attention to give you unmatched performance.

Design

The **X8** embodies strength and style all in one. Sleek, dynamic lines give the tractor an aggressive yet classy look. The functional design of the sloping bonnet with its rounded sides further improves front visibility. Designed with utmost attention to every detail, the **X8** makes farmers and contractors excited and proud to drive it.



**HIGH-GRADE
AUTOMOTIVE-STYLE
FIT AND FINISH**

**SWIVEL SEAT
WITH HEATING AND
VENTILATION**

**ELECTRICALLY
ADJUSTABLE
DASHBOARD AND
STEERING WHEEL**

Visibility

- › The innovative Clever Cab features a four-post design with 14 percent more glass area and rear hinged doors for all-round visibility.
- › The 210-degree windscreen wiper and the heated and tinted rear window with up to 75-degree opening angle and new, larger and more comfortable handles further improve visibility.
- › The Clever Cab features new, large telescopic and heated rearview mirrors that can be adjusted from the driving position. The wide-angle mirrors allow a better view of blind spots.

Comfort

- › The electrohydraulic semi-active cab suspension system reduces vibrations and improves stability, including on rough terrain.
- › Wide, well-spaced steps, daytime running lights integrated into the new headlamps and a hide-away buddy seat make access to the cab safe and easy.
- › The cab interior offers more room in every direction with 8 cm extra space for the head and 12 extra cm for the seat's backward movement, providing additional comfort for tall operators.
- › A high-grade sound insulation system allows a noise level of only 68 dB. This low sound level is achieved through an accurate cab design: the frame is constructed using robotic welding; the engine, transmission and hydraulic system are perfectly sound insulated; cable passages are sealed to stop dust and noise from entering the cab.

- › The cab interior features an automotive-style fit and finish with easy-clean soft-touch materials.
- › The Alcantara upholstered swivel seat with active dynamic air suspension, fully automatic height adjustment, heating and ventilation ensures ultimate driving comfort whatever the outdoor conditions. The headrest can be adjusted to improve the operator's field of vision and the armrest moves together with the seat for maximum comfort of operation.
- › The steering wheel and the dashboard are electrically adjustable in tilt and depth to suit the operator's needs. The electronically controlled steering system makes driving easier and improves working accuracy and comfort, resulting in greater productivity.
- › The multifunctional armrest can be ergonomically adjusted to suit the individual user's needs.
- › The tinted, transparent roof hatch can be opened to provide extra visibility during work.



**+8CM
HIGHER
CAB**

**+14%
LARGER
GLASS AREA**

**-6°
HIGH
THERMAL
COMFORT**

**68dB
EFFICIENT
SOUND INSULATION**

**210°
LARGE
WIPER FIELD**



Controls

- › The new multifunction armrest houses all the main controls for intuitive and comfortable tractor operation. The other controls are logically and ergonomically arranged on the right-hand console.
- › The EasyPilot joystick has an ergonomic grip and features clear, easily configurable functions.
- › The large 12-inch touchscreen monitor features tablet-like graphics for easy configuration and convenient control of all tractor's functions. The touchscreen monitor also allows the user to control two rear view cameras and to configure and handle headland management operations via the intuitive MyHMF menu, including when the tractor is stationary. The new aluminium monitor bar allows the display to be easily repositioned.

Accessories

- › Available accessories include: 8.6L refrigerated compartment, in-cab storage compartment, bottle holder, 12 V sockets for charging mobile devices, internal mirror.
- › Powerful Alpine touchscreen radio with DAB+, 4 Alpine 200 Watt RMS speakers, Android Auto and Apple CarPlay, Bluetooth, integrated microphone, and 2 USB ports.

Climate control

- › The efficient automatic climate control system features nine vents arranged in such a way as to provide 360-degree air distribution, creating an ideal working environment in all weather conditions.
- › The Clever Cab adopts a technologically innovative glazing. The Comfort Sky® coating, developed by Saint-Gobain, improves UV protection and increases resistance to temperature rise within the cab, resulting in a reduction of 6°C compared to ordinary glass.



12
FULL LED
WORK
LIGHTS

Lighting

Twenty fully restyled, adjustable full LED work lights and four full LED headlamps illuminate the entire work area with a high-contrast, daylight-like light, providing optimum lighting at night and in low light conditions. Located at the rear of the cab, two long-range lights illuminate the end of the implement to ensure safe operation. Other long-range lights on the bonnet illuminate the field below. In addition, the MyLights function allows two different light configurations for optimal lighting when working beside threshers or other similar machines.





CLEVER CAB: A NEW GEOMETRY OF SPACE

The new Clever Cab offers more space for the operator. The clever four-post design has increased the glazed area by 14 per cent to allow full view of the implements and of the entire work area. Interior space has also been increased, particularly in the area around the chest and head of the driver, with 8 cm extra height. The seat travel has been extended by 12 cm towards the rear side. Storage areas are all built in to keep the working space uncluttered.

CAB SUSPENSION SYSTEM

To make the farmer's work less tiring, McCormick has developed Cab Suspension, a new electrohydraulic semi-active cab suspension system which isolates the tractor body from wheel vibrations induced by uneven ground conditions. Cab Suspension increases tractor stability on all terrains, enhancing ride comfort.

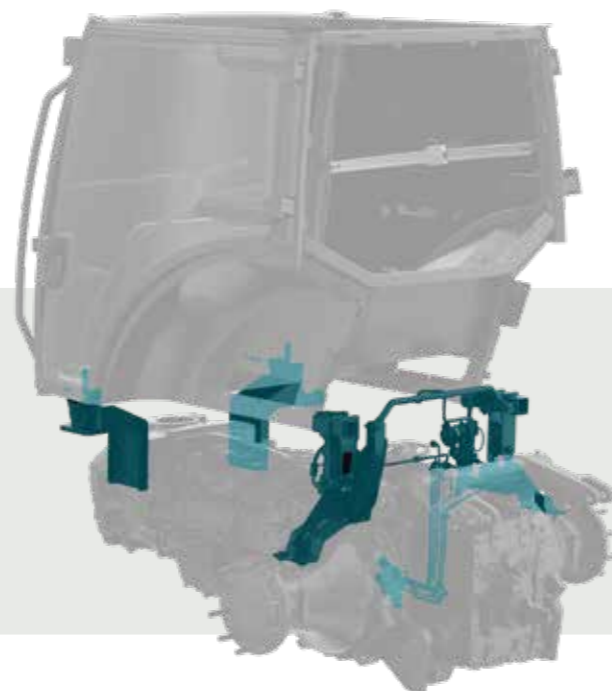

EASY AND SAFE CAB ACCESS

Wide, well-spaced steps, large doors and a fold-away buddy seat make access to the cab easy and safe. In addition, the daytime running lights integrated into the new headlamps and delayed light switch off ensure safe entry and exit at night.





Multifunction armrest: the right hand of efficiency

Designed from a careful analysis of the work sequences, McCormick's new ergonomic multifunction armrest groups together all the main controls in a logical manner to allow intuitive and comfortable tractor operation. Less frequently used controls are located on the right-hand console, which also houses two 12V sockets and one ISOBUS connection. Button-controlled functions can be automated and replicated on the EasyPilot joystick to allow customised operation.



MYFUNCTIONS

The new MyFunctions menu provides fully customisable control of tractor and implements, allowing the operator to configure and save up to five different functions via the DSM touch screen monitor. All controls have also been ergonomically repositioned on the multifunction armrest to improve comfort and ease of operation.

MYHMF

The MyHMF menu enables the operator to create and modify headland management sequences via the DSM monitor, even when the tractor is stationary. Two buttons on the multifunction armrest allow fast selection and activation of the created sequences.

MYLIGHTS

The roof of the new Clever Cab can be equipped with 12 adjustable full LED work lights to provide powerful 360-degree illumination for working at night. All work lights can be configured via the MyLights menu on the DSM touch screen display.

MYTRACTOR

With the MyTractor menu, the user can save the tractor control settings, such as MyFunctions and MyHMF, and recall them simultaneously without the need to reconfigure the menus.

MYUSER

The MyUser interface allows all tractor control settings, such as menus, configurations, or the language, to be saved and linked to the user's profile for ultimate versatility in multi-operator applications.

Large driver's seat for cutting-edge comfort

Inspired by the automotive design, the large driver's seat is upholstered in Alcantara fabric and equipped with air suspension, automatic height adjustment, heating and ventilation. A filter system keeps the surface dry at all times for pleasant seating in all weather conditions. The headrest can be tilted to provide a better view of the work area, and the armrest moves together with the seat for full operating comfort. The seat rotates 30 degrees to the right and 10 degrees to the left, making work easier. Passengers can also travel in comfort thanks to an innovative buddy seat with a higher backrest and larger seat which neatly folds away to allow easier and safer access to the cab.



Convenient, dedicated storage compartments

Objects, telephones, food, bottles and glasses can be conveniently placed in dedicated compartments in the Clever Cab, just like in an office. All compartments are built in, so as not to obstruct the operating space, and some of them can be opened. The refrigerated compartment has a capacity of 8.6 litres.



EFFICIENT AND CONVENIENT AUTOMATIC CLIMATE CONTROL

The efficient automatic climate control system, integrated in the cab roof, allows the user to choose the desired temperature. Nine carefully arranged vents distribute the air evenly within the cab, creating an ideal working environment whatever the outdoor weather conditions. This system offers a number of advantages: the climate control adjustment button is conveniently located in front of the driver; the system is designed to reduce airflow noise; and lastly, the filters are easy to clean and positioned so as to minimise soiling.



7-INCH MULTIMEDIA RADIO WITH DAB+

The Alpine multimedia radio, with its high-resolution 7-inch touchscreen, is a true concentrate of technological innovation:

- › **DAB+**: In addition to offering exceptional noise-free sound, the DAB+ radio system offers a much wider choice of radio stations compared to FM radio and allows the user to easily select channels from an alphabetical or genre list of stations.
- › **Apps**: The Alpine radio system offers a number of apps with advanced functions, such as real-time traffic information, compatible with Apple CarPlay or Android Auto.
- › **Bluetooth**: Allows driver to make hands-free phone calls while working and to stream music through the Clever Cab's speakers.
- › **Sound**: The high-end 200 W RMS four-speaker sound system delivers powerful, clean and detailed sound across the entire frequency range, from deep bass to high treble.



OVER 313 HORSEPOWER TO PULL YOUR BUSINESS FORWARD

The X8 gives you all the power you need: you can pull up to 40 tons without effort!
The X8 can pull up to 40 tons in complete safety. In addition, it can reach 50 km/h at 1580 rpm, significantly reducing fuel consumption.

You can count on more traction and reduce fuel consumption by up to 12%.
The new Stage V FPT NEF 67 engine that powers the X8 tractor dispenses with the need for a particulate filter; this means less components, less maintenance and consequently less costs. Without a DPF, which is fuel consuming and loses efficiency over time, requiring periodic replacement, the engine is more powerful and more reliable.

In addition, having the engine located within a chassis moves the tractor's centre of gravity forward, which improves front wheel grip thereby increasing power to the ground. Better traction improves fuel economy reducing consumption by up to 12 percent compared to competitive engines.

It only takes 5 minutes to clean the radiator.

McCormick has the goal to simplify all those operations that are necessary to maintain your tractor in good working order. The coolers located in front of the radiator open fully from a single latch allowing quick, easy and accurate cleaning. This maintains the efficiency of the cooling system ensuring smooth engine performance.



NEW FPT NEF 67 ENGINES: PLENTY OF PULLING POWER IN THE FIELD



The **X8** tractors are powered by new FPT NEF 67 6.7-litre, 6-cylinder turbo intercooled engines with multivalve technology and electronic common rail injection system. The eVGT variable-geometry turbocharger provides optimum engine performance and fast response to load changes. The maximum torque is available already at 1400 rpm. The HI-eSCR2 exhaust gas aftertreatment system ensures compliance with Stage V emissions regulations.

The **X8** range comprises two models:

- › **X8.627** VT-Drive with 273/201 hp/kW;
- › **X8.631** VT-Drive with 313/230 hp/kW.

The engine is located within a rugged chassis which helps reduce noise and vibration levels within the cab. The electronically controlled Viscotronic fan improves engine cooling efficiency while reducing fuel consumption and noise.

The new FPT NEF 67 is an advanced engine designed to offer farmers simplicity, reliability and durability.

HIGHLIGHTS

- › Up to 313 hp of power.
- › eVGT variable-geometry turbocharger and electronic engine management; common rail and intercooler.
- › Viscotronic fan for more efficient engine cooling, improved fuel economy and quieter engine operation.
- › Up to 40% torque backup.
- › HI-eSCR2 exhaust gas aftertreatment system meeting Stage V emissions regulations.
- › Engine located within a rugged chassis.
- › Easy-fill 550L fuel tank and 70L AdBlue tank.
- › Engine brake function for enhanced braking performance.
- › Radiator coolers open out to allow easier and faster cleaning.
- › Best In Class system to reduce scheduled maintenance by 50%, saving time and costs.

Powerful variable-geometry turbocharger

Thanks to the eVGT variable-geometry turbocharger, the engine of the **X8** delivers high torque values even at low engine speeds, providing superior performance with excellent fuel economy.

Engine brake function for safer braking performance

By activating the engine brake function through a foot pedal conveniently located between the clutch and brake pedals, a motorised throttle valve located on the turbocharger improves the tractor braking performance.

Electronically controlled Viscotronic fan

The electronically controlled Viscotronic fan adjusts automatically its speed based on engine temperature and load for optimal cooling efficiency. It further reduces engine consumption and noise levels, minimising power loss and improving traction.





HI-eSCR2 system for cutting polluting emissions

The HI-eSCR2 exhaust aftertreatment system allows the X8 tractors to meet Stage V emissions regulations. This technology integrates the SCR catalyst with a maintenance-free filtering device, doing away with the EGR system. This improves engine performance while reducing operating costs.

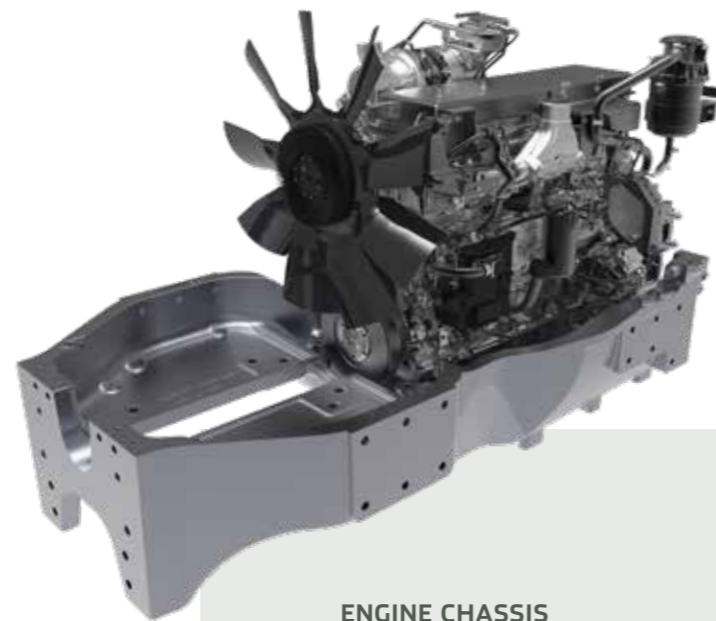

ENGINE CHASSIS FOR MAXIMUM EFFICIENCY

The FPT NEF 67 engine is located within a rugged chassis and mounted on silent block rubber mounts to isolate both cab and transmission from vibrations and noise. This solution moves the tractor's centre of gravity forward, improving the vehicle's balance while increasing traction.

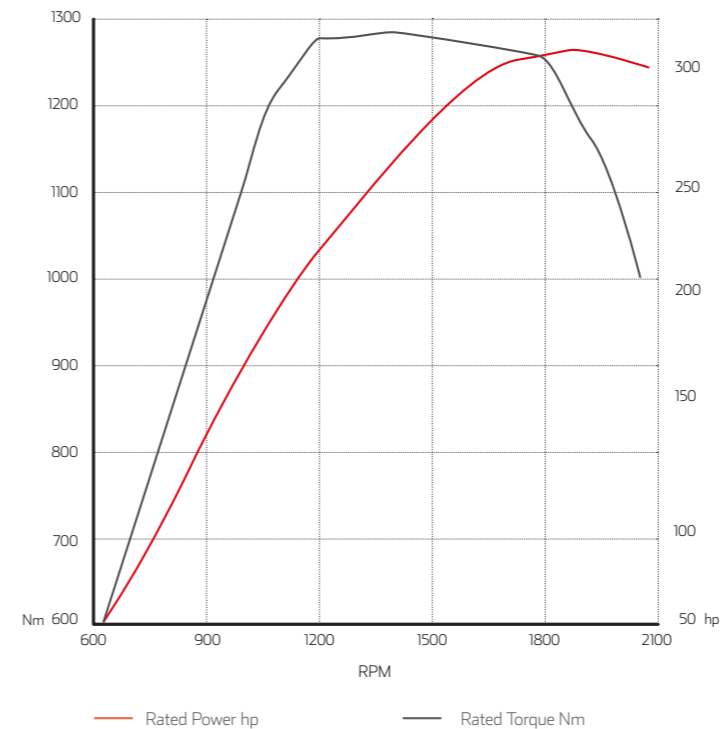

McCORMICK X8	MAX POWER HP / KW	MAX TORQUE NM
X8.627 VT-DRIVE	273 / 201	1173
X8.631 VT-DRIVE	313 / 230	1282

LARGER TANKS TO MINIMISE DOWNTIME

The cab access steps have been integrated into the fuel and AdBlue tanks enabling their storage capacities to be increased to 550 litres and 70 litres, respectively. This extends the tractor's operating range, reducing refuelling frequency.



BEST IN CLASS SYSTEM, REVOLUTIONISED MAINTENANCE

The Best In Class system is based on an innovative filter concept that doubles the intervals between maintenance operations, extending them from 500 to 1000 working hours. This results in significant time and cost savings.





VT-DRIVE, THE CONTINUOUSLY VARYING TRANSMISSION

With the VT-Drive transmission, the X8 responds promptly to your commands. Combining a powerful engine with a VT-Drive continuously variable transmission, the X8 delivers fast acceleration and excellent responsiveness.

You work with the most advanced variable transmission on the market. The VT-Drive continuously variable transmission offers proven reliability in a wide variety of applications. Now, an innovative next-generation four-stage technology projects the VT-Drive transmission further into the future.

VT-Drive: once you've tried it, you can't do without it. The VT-Drive continuously variable transmission is quite easy to use: you just need to release the parking brake, select the direction with the power shuttle and step on the gas pedal. This simplicity of operation, combined with clear controls and an intuitive touch screen interface, makes working with the X8 stress-free and efficient.

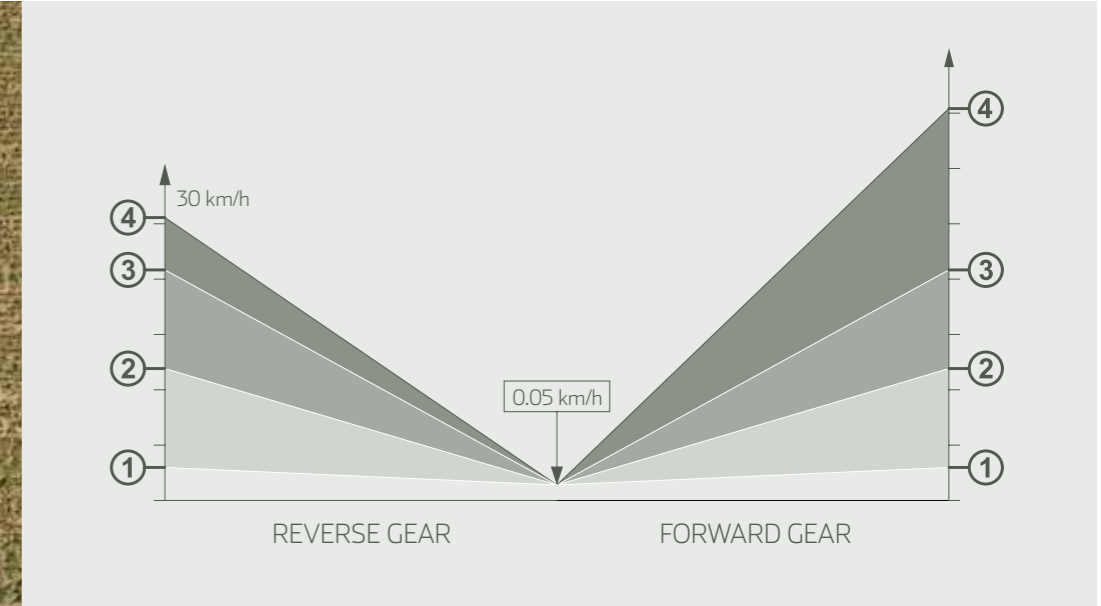

HIGHLIGHTS

- › VT-Drive continuously variable transmission with controls grouped on the EasyPilot controller.
- › The VT-Drive transmission does not require the use of the clutch pedal.
- › Soft acceleration, optimum speed, constant traction.
- › Remote Power Shuttle for fast and easy forward/reverse shifting.
- › The simple operation of the VT-Drive transmission allows greater concentration on the job at hand.
- › Lower fuel consumption and reduced operating costs.
- › Top speed: up to 50 km/h at 1580 rpm.

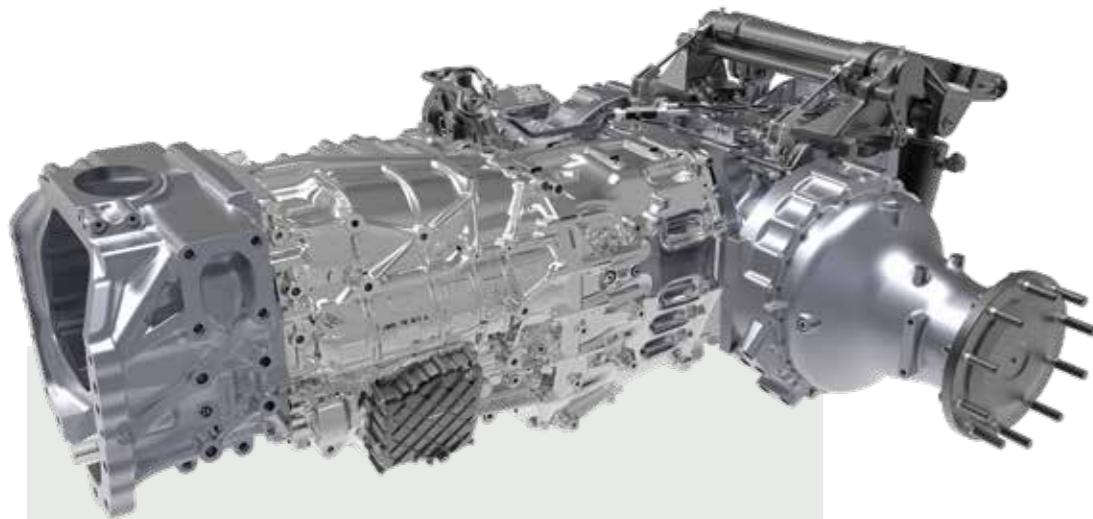

VT-Drive, the continuously variable transmission from McCormick

Powerful and versatile, the **X8** tractor will handle all kinds of tasks and field conditions efficiently. The VT-Drive continuously variable transmission is designed to cater to the needs of modern agriculture. Combining the FPT NEF 67 engine with the VT-Drive four-stage continuously variable transmission with four planetary gear trains and oil-cooled clutches, the **X8** provides fast acceleration and excellent responsiveness, making work easier and more efficient. The VT-Drive transmission offers four speed ranges with advance speeds from 40 m/h to 50 km/h for maximum productivity in any application.

The VT-Drive gives you a choice of four speed ranges

With its innovative four-stage technology, the VT-Drive transmission from McCormick sets a benchmark in continuously variable transmissions. Using a four-stage instead of the conventional two-stage CVT transmission offers real benefits to farmers and agricultural contractors looking for a multi-purpose tractor capable of ensuring maximum productivity in all working conditions.

The choice of the speed range that best suits the task at hand makes working with the **X8** more accurate and comfortable:

Range 1	Creeper	0.5 – 3 km/h
Range 2	Field 1	0.5 – 12 km/h
Range 3	Field 2	0.5 – 21 km/h
Range 4	Transport	0.5 – 40 or 50 km/h

The VT-Drive transmission features four operating modes:

- 1. Auto Mode** - The electronic unit adjusts the engine rpm and transmission ratio according to the potentiometer settings to achieve the required speed.
- 2. Manual Mode** -The operator sets the engine speed using the hand throttle. The electronic unit adjusts the transmission ratio to achieve the required speed.
- 3. PTO Mode** - The operator sets the engine speed using the hand throttle. The electronic unit adjusts the transmission ratio to achieve the required speed with the PTO activated.
- 4. Cruise Mode** - The operator selects the tractor travel speed which remains constant.



ELECTROHYDRAULIC POWER SHUTTLE

The reverse power shuttle allows the operator to automatically shift from forward to reverse without using the clutch pedal, by simply operating the shuttle control lever adjacent to the steering wheel. The shuttle response is electronically modulated and adjustable by the operator if required for different tasks.



EasyPilot joystick, designed for comfort and productivity

Functional and ergonomic, the EasyPilot multifunction controller provides easy and intuitive control of the VT-Drive transmission, allowing the operator to drive the tractor and operate the implements with maximum ease and comfort. The EasyPilot allows the operator to configure via the intuitive MyFunctions menu up to five different functions on five pushbuttons present on the controller. Configurable functions include the speed cruise control; headland operations, configured from the MyHMF menu; automatic forward/reverse shifting without using the steering-column shuttle lever. All functions are clearly displayed on the instrument panel and on the touch screen display.

THE X8 PUTS ALL THE POWER TO THE GROUND

Maximum power transfer to the ground.

The X8 uses all of its 313 horsepower both in the field and on the road. Thanks to its engine located within a rugged chassis and its heavy-duty front axle with independent wheels, the X8 is the tractor that transfers more power to the ground in its class.

Optimum manoeuvrability for turning in tight spaces.

The X8 is not only a powerful tractor, but it is also compact and easy to handle thanks to a wheelbase of just 3 metres. The innovative design of the chassis allows for a turning circle of only 7 metres, the tightest in its class.

Minimum soil compaction.

The engine, located within a rugged chassis and mounted on silent blocks, moves the tractor's centre of gravity forward, ensuring optimal weight distribution. This reduces vibrations and soil compaction to a minimum and enables all the engine power to be transferred to the ground for enhanced traction performance.



ENGINE BRAKE, MORE SAFETY AND MORE ECONOMY

The X8 features a high-performance engine brake that increases braking capability, enabling the tractor to slow down in a controlled manner. Reduced brake use will extend brake life, reducing maintenance costs. The engine brake provides better control on steep inclines and rough terrains for maximum safety in any situation.

Traction, manoeuvrability and comfort on all terrains

The X8 is built to tackle tough terrain and steep inclines with ease. Thanks to its engine mounted on chassis and its rugged front axle with independent wheels, this tractor puts all its 313 horsepower to the ground. The X8 combines outstanding traction and manoeuvrability, ensuring optimum grip and stability for superior driving comfort in the field and on the road.

The rugged front axle is equipped with full locking differential and electrohydraulic four-wheel drive. High-capacity wet multi-disc rear axle brakes ensure safe controlled stopping power. Also, when braking, the four-wheel drive engages automatically, which in turn brakes the front axle for efficient braking on all four wheels. The X8 tractor is further equipped with a brake boosting system that reduces the effort required by the operator while improving driving accuracy and safety. The X8 is fitted with 900/60 R42 (Ø 2.15m) tyres that transfer all the engine power to the ground. The tyres' large contact area, along with the EazyGrip system for precise control of tyre pressure, reduces soil compaction significantly.



PARALLELOGRAM FRONT AXLE FOR ENHANCED PERFORMANCE

The electronically controlled front axle features a centre-pivot suspension system with a four-bar linkage mechanism that provides better grip and greater stability compared to conventional axles, resulting in improved driving safety. This system, which allows the operator to adjust front axle ground clearance to facilitate ploughing or other similar operations, improves traction and manoeuvrability in the field and makes for faster travel speeds, added safety and greater ride comfort on the road.

McCORMICK WEIGHTS FOR PERFECT BALANCE

McCormick offers a new range of weights that are quick and easy to attach and remove, allowing the X8 to put to the ground its 313 hp of sheer power. Options available include sets of 600 kg and 1200 kg rear axle weights and a 1800 kg monoblock weight for front hitch.



- 1 1800 kg monoblock front weight
- 2 Set of 600 kg rear weights
- 3 Set of 1200 kg rear weights



EAZYGRIP MINIMISES SOIL COMPACTION

A correct tyre pressure preserves the structure of the soil maintaining fertility over time. The EazyGrip technology allows the operator to adjust tyre pressure for field work or road use via the touch screen monitor and the ISOBUS system. A correct tyre pressure minimises soil compaction and improves traction. It also reduces tyre wear while improving fuel economy. EazyGrip will maintain top performance with the use of low-pressure tyres such as the I-Flex tyres that use pressures up to 1 bar or the V-Flex tyres that can use pressures below 1 bar.

AUTOMATIC GREASE SYSTEM FOR TOTAL EFFICIENCY

The Automatic Grease System is designed to simplify, speed up and improve the maintenance of the X8. The system allows all lubrication points to be lubricated from a single source in order to maintain all mechanical components in good working order.



HIGH-PERFORMANCE HYDRAULICS

You work with the most powerful rear hitch in its class...

Powerful and reliable, the rear hitch of the **X8** provides a lift capacity of up to 12000 kg and gives the operator precise control of the implement during headland turns and road transport.

... and with the most efficient front hitch.

Integrated into the tractor chassis, the front-mounted hitch of the **X8** delivers plenty of lifting power, enabling easy handling of heavy implements. This design allows the hitch to transfer the force evenly over the entire tractor driveline, thereby delivering impressive lifting capability.

The hydraulic system is tailored to your needs.

The **X8** features a closed centre, load sensing hydraulic system that regulates the supply of oil to the remote valves according to the engine load. The remotes are all electronically operated and can be configured from the touch screen display. Controls can also be customised. Designed to provide high-flow capability, the hydraulic circuit of **X8** features high-quality components and provides wide configuration flexibility to meet the specific needs of farmers and contractors.



HIGHLIGHTS

- › Closed centre hydraulic system with either 160 l/min or 212 l/min variable displacement pump.
- › Electronically controlled rear hitch with up to 12000 kg lift capacity.
- › Front hitch with up to 5000 kg lift capacity as standard.
- › Electronically controlled three-speed PTO: 540Eco/1000/1000Eco rpm.
- › Front PTO: 1000Eco rpm.
- › Up to 11 electrohydraulic remote valves: 6 at the rear, with a 3-way flow divider, 3 at the front and 2 mid-mounted.

THE X8 KNOWS HOW TO PUMP UP YOUR PRODUCTIVITY



The X8 tractors feature a closed centre hydraulic system with variable displacement pump. This means that the pump always delivers exactly the quantity of oil that the system requires, thereby eliminating unnecessary power waste. The system supplies 160 l/min to the hitch and remote valves and 115 l/min to the electronic steering system, allowing for simultaneous operation of all hydraulic functions. A pump with up to 212 l/min flow rate is also available to provide high-flow capability.

The X8 can be fitted with up to eleven electrohydraulic remote valves: six at the rear, with a 3-way flow divider with six push-pull quick-couplers; three at the rear, including one dedicated to the front hitch; and two mid-mounted for the use of a front loader. The system, equipped with high-quality components and fully customisable controls, is electronically controlled and can be configured from the touch screen display. All these hydraulic features allow farmers and contractors to easily tailor their tractor to their specific needs and preferences.



Rear PTO for maximum efficiency in any application

The X8 range has been designed to operate in a variety of conditions with heavy, power-demanding implements. The driveline design provides modulated PTO engagement, protecting implements and ensuring minimal power loss. The PTO offers three electronically selectable speeds: 540Eco, 1000 and 1000Eco rpm. External PTO, hitch and remote valve controls are also located on the rear fenders, making it easier to attach implements from the ground.

AUTO PTO FUNCTION

The Auto PTO feature will automatically disengage and reengage the PTO at three-point linkage heights set by the operator. This gives the operator precise control of the implement during headland turns.

Customised control of remote valves

The rear remotes are intuitively controlled via the DSM touch screen display. This allows the user to fully customise flow rates, modes of operation and controls. The X8 tractor can be fitted with up to eleven remote valves that can be controlled from the multifunction controller. Three valves are operated via fingertip controls integrated on the multifunctional armrest. Also located on the armrest is a fingertip selector for operating the flow divider. A mini-joystick controls up to six remotes that can be programmed via the DSM touch screen monitor and allow the operator to control both the front hitch and front loader and to operate the ISOBUS system.



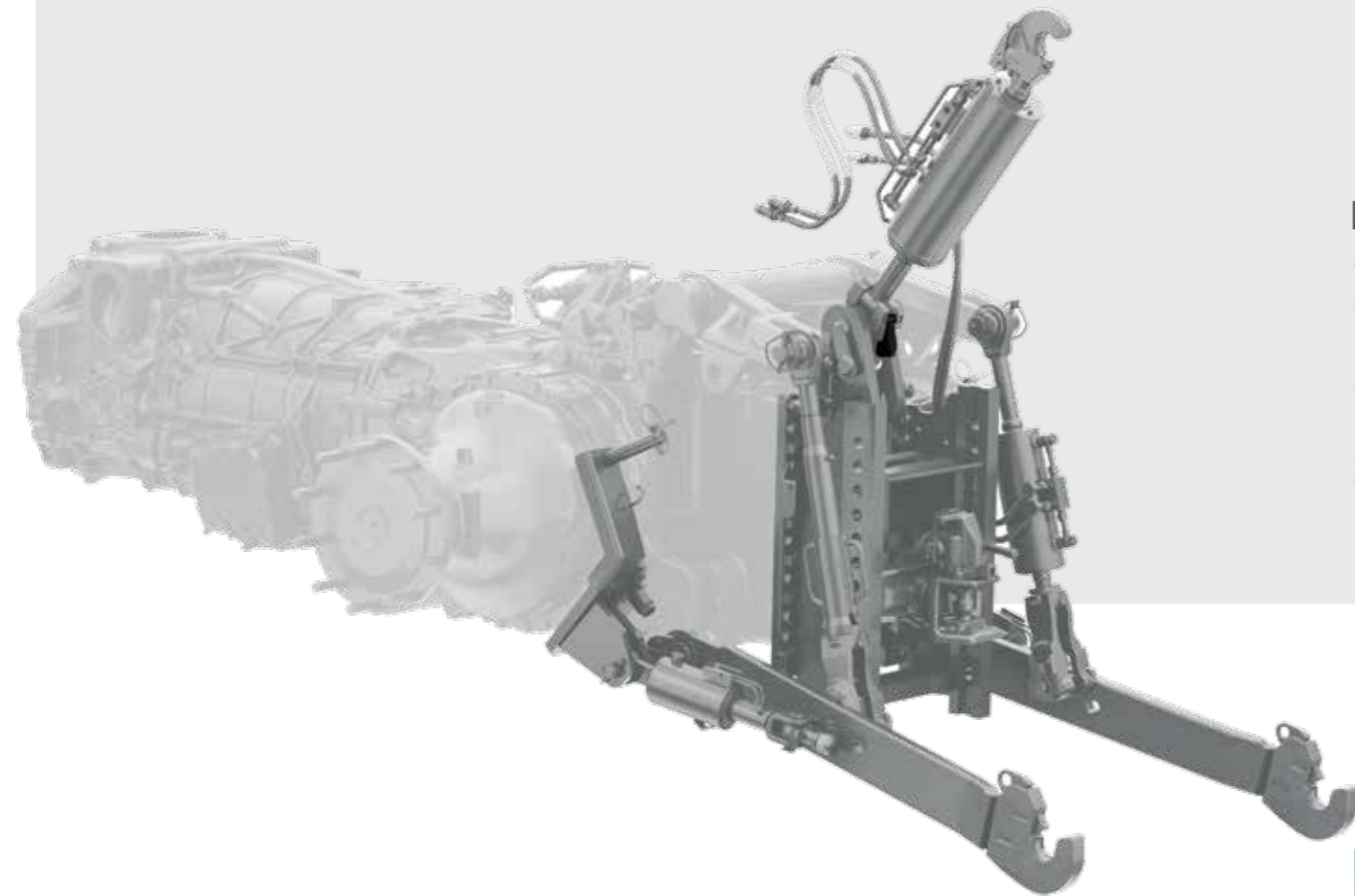

Electronic rear hitch

The EasyPilot controller enables convenient and intuitive operation of the rear hitch and implements. The electronic management provides simple and safe operation of the system. Offering a maximum lift capacity of 12000 kg, the three-point hitch Category 3 or 4N is equipped with lower link draft sensing for accurate implement control. The PTO and hitch controls on the rear fenders offer additional, easy-to-use functions such as control of one remote valve, rear hitch fast raise/lower, rear PTO and engine speed memory.

Front hitch and PTO

The front hitch of the X8 is capable of lifting up to 5000 kg. The front PTO has a speed of 1000 rpm.



HITCH DAMPING SYSTEM FOR PROTECTION OF TRACTOR AND OPERATOR

The X8 is designed to handle heavy-duty implements with maximum efficiency. During headland turns and transport operations, heavy implements generate shock loadings. Both the rear and front hitch of the X8 feature a damping system with two nitrogen charged accumulators that minimises tractor pitching when travelling with raised implements, making for a smoother and more comfortable ride.



FLEET & DIAGNOSTIC MANAGEMENT: PROFIT ASSURED



McCormick, a brand globally recognised as synonymous with high performance and cutting-edge technology, equips all its tractors with remote management and diagnostic capabilities. The McCormick Fleet & Remote Diagnostics Management system helps farmers make informed data-driven decisions that will reduce their operating costs while increasing the efficiency and productivity of their farms. This advanced solution is based upon four key functions:

1. Real-time fleet monitoring.
2. Data analysis.
3. Scheduled maintenance and remote diagnostics.
4. Activity history.

McCormick is fully committed to addressing the needs of modern agriculture with concrete and effective solutions. The McCormick Fleet & Remote Diagnostics Management system helps farmers manage their farms more efficiently by favouring the most appropriate choices in order to maintain their tractors in good working order, optimise their work and increase their business profitability.

1. Real-time fleet monitoring: The system displays at any time the exact location of each tractor in a fleet and, using the Geofencing technology, notifies whenever a vehicle enters or exits a specified zone. It also measures the efficiency of each tractor by checking parameters like speed, engine hours and RPMs, fuel and urea levels, average consumptions and work progress.

2. Data analysis: The data coming from the tractors allow the system to measure the productivity of each vehicle in the fleet and the farm's operating profit. These data are essential to monitor and reduce costs, make predictions, organise work plans and take informed decisions.

3. Scheduled maintenance and remote diagnostics: The tractor fleet is managed in a simple and fast manner. In case of failure, our after-sales service intervenes remotely in real time in order to adopt the most appropriate solutions and to improve the tractor's performance, thereby reducing downtime and extending the equipment's life.

4. Activity history: This function delimits the work areas and stores the data of the activities performed. This allows the user to better organise the work, increase efficiency and productivity and maximise profitability.



McCORMICK FARM TECHNOLOGY FOR A MORE PRODUCTIVE FARM

McCormick improves the efficiency of your farming operations. But not only this: McCormick Farm connects your tractor to an intelligent and intuitive farm management system. This brings farmers a number of benefits in terms of time saving, work simplification and enhanced performance.

360-degree management solutions for your farm

McCormick Farm supports more than 400 different crops and allows virtually all tasks on the farm to be accomplished, including crop management, tracking and planning of field activities, advice on crop protection and irrigation practices, creation and exchange of prescription maps with monitoring of costs and sustainability, export of documents.

Connected to your McCormick

By connecting your McCormick to the McCormick Farm app, you can view performance and reports on the farming activities carried out in the fields. In addition, you can display prescription maps, A/B lines, boundaries and obstacles.

Always at your fingertips

Whether in the field or on the farm, McCormick is always at your side, thanks to the McCormick Farm app for smartphone and tablet. And if you want to run your business from your computer, you may access the web version synchronised with the mobile devices.

Simple and intuitive

McCormick Farm is designed to be clear and user-friendly. A support chat answers questions about the use of the app.





PRECISION STEERING MANAGEMENT, FOR PRECISION PERFORMANCE



Precision farming has been in existence ever since man started to cultivate land. Today, thanks to technological development, precision farming is carried out with innovative tools that improve efficiency and increase productivity. McCormick uses the innovative PSM (*Precision Steering Management*) system, a set of integrated devices for satellite-assisted guidance that can be managed from the tractor cab via a simple touchscreen, on which the tasks to be performed in the field can be easily imported. Thanks to the precise automated steering control, the tractor only deviates 2 cm from the desired route, eliminating overlaps. This helps operators work with more speed and accuracy and reduces operating costs and environmental impact while raising efficiency and productivity in the field.

ISOBUS & ISOBUS GREEN MAKE YOUR WORK SIMPLE AND EFFICIENT

In 2015, Argo Tractors received the AEF ISOBUS certification. The **ISOBUS** system is the standard protocol through which the on-board computer communicates with the tractor and implements. The automatic control of **ISOBUS**-compatible implements allows variable-rate applications to be delivered through prescription maps generated by McCormick Farm. All **ISOBUS**-compatible implements are managed

via a DSM 12" touch screen monitor to improve operating efficiency and productivity. McCormick is a leading participant in the innovative **ISOBUS** Green project. This project allows farmers to retrofit their mechanical implements with the technology so as to connect them to the tractor's **ISOBUS** system. This solution maximises the efficiency of every implement.

Precision Steering Management & ISOBUS: all-round benefits in the field

The **Precision Steering Management** and the **ISOBUS** system are innovative technologies adopted by McCormick to increase efficiency and productivity while improving comfort and safety:

- › All implement activities are managed with a high level of accuracy, including in automatic mode.
- › Difficult manoeuvres are simplified, thereby reducing operator fatigue.
- › When the driver must attend to driving and simultaneously control the implements, the PSM satellite-based guidance system will allow them to fully concentrate on the task at hand.
- › The satellite guidance system tracks field operations with maximum accuracy.

Thanks to the RTK protocols, the automatic steering allows a deviation of only 2 cm from the set route.

- › Reducing the travelled distance in the field reduces tractor and implement wear and tear and saves fuel.
- › The use of variable-rate applications based on prescription maps generated by the McCormick Farm platform eliminates skips and overlaps, minimizing product waste. Variable-rate technology reduces overuse of water, seed use by 10%, fertiliser use by 16% and herbicide use by up to 60%.
- › Chemical residues are also reduced with significant benefits for the environment.
- › Reports and pre-setting operations are simpler and can be done autonomously without recourse to skilled personnel.

ARGO TRACTORS FLEET ROUTER MANAGEMENT SIMPLIFIES YOUR WORK

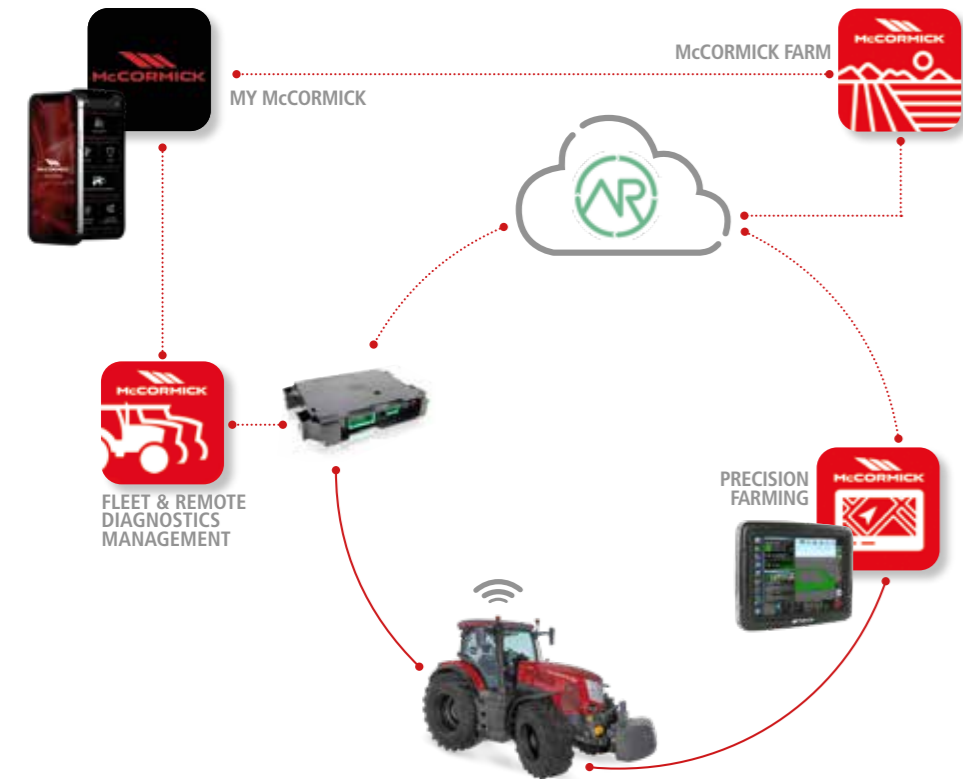

The new digital technologies have rapidly multiplied the sources and destinations of data. Today, it is paramount for both small farmers and large agricultural businesses to enable different systems to communicate with each other. For this reason, in 2023, Argo Tractors has become an **Agrirouter** certified partner with the account Argo Tractors Fleet Router Management. **Agrirouter** is a universal data exchange cloud platform that allows the interchange of information between machinery, equipment and software of different manufacturers. **Agrirouter** links different sources and platforms, simplifying the operating processes and ensuring data confidentiality. The operator keeps everything under control with a single system. By connecting the tractor to the implements, including those from different manufacturers, and to the McCormick Farm platform, a simple and efficient integrated management of both machinery and farm is achieved.

MY McCORMICK APP, THE McCORMICK WORLD IN YOUR HAND

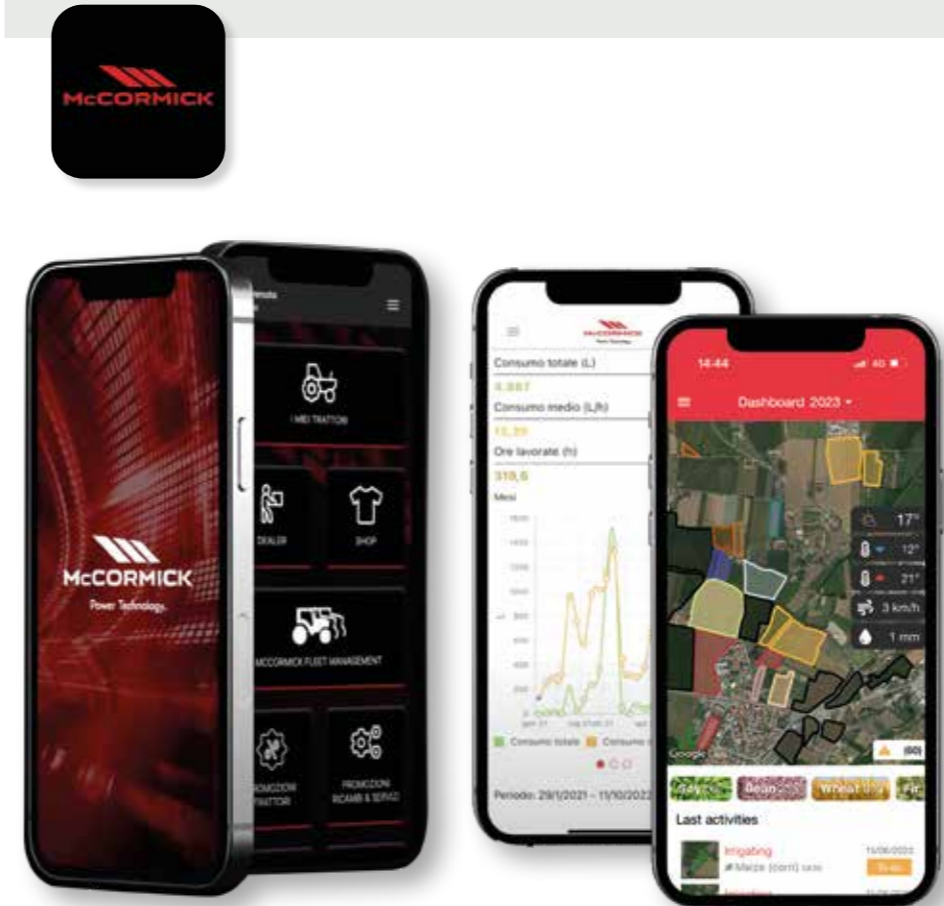

The intuitive **My McCormick** app offers the user a 360-degree immersive experience through our Digital Solutions. The **My McCormick** app gives you easy access to all McCormick digital services, allowing you to stay connected with the company through news, insights, offers and customised information. With **My McCormick** you can:

- > Register your McCormick tractor fleet and access the scheduled maintenance program.
- > Access the McCormick Fleet & Remote Diagnostics Management system.
- > Access the McCormick Farm platform.
- > Enter the online shop.
- > Stay updated with the very latest news and events from the McCormick world.
- > Stay informed on promotions and offers of tractors, original spare parts and services.
- > Stay updated with new products, promotions and events from the nearest dealer.

McCormick is always at your side. With the **My McCormick** app you have the whole McCormick world at your fingertips, so you stay informed and optimise your work making it more efficient and productive.



QUICK MAINTENANCE TO GET YOU UP AND RUNNING IN NO TIME

Designed to deliver maximum efficiency and reliability, the X8 range offers a variety of solutions to simplify and expedite maintenance.

- 1.** The tilt-up bonnet opens wide to provide easy access to the engine compartment for fast and easy, tool-free maintenance.
- 2.** The oil filler cap is placed in the lower part of the engine, so topping up of engine oil can be done without opening the bonnet.
- 3.** The engine air filter is conveniently placed to facilitate cleaning and replacement.
- 4.** The cooling radiators open fully from a single latch to allow fast and easy cleaning.
- 5.** The fuel and AdBlue tanks are conveniently placed to allow quick filling. Tank caps have different colours to avoid mix-up.

- 6.** The in-cab air filter is easily accessible for maintenance.
- 7.** The oil level in the transmission can be conveniently checked through the transparent oil filler cap with level gauge placed on the tractor's rear end.
- 8.** The windscreen wiper fluid reservoir is located on the rear of cab.
- 9.** Maintenance intervals have been doubled from 500 to 1000 hours.
- 10.** The McCormick Power Service function of the My McCormick app will remind you of the maintenance checks to be done and the spare parts required to keep your X8 in good working order.



McCORMICK ORIGINAL SPARE PARTS: FIRST IN PRODUCTIVITY

Although it works hard, your McCormick tractor always looks good as new. With McCormick original parts time seems to have stopped. Our original spare parts are an integral part of our scheduled maintenance and extended warranty program. Developed by the same engineers who design and manufacture the McCormick tractors, genuine McCormick parts are designed and manufactured to the highest quality standards to ensure reliable and safe performance over time.

The strong points of McCormick original spare parts are the following:

- › **Speed:** Spare parts are always shipped within 24 hours of order receipt.

- › **Quality:** Each part comes with a 12-month warranty and is marked with a tamper-proof hologram that certifies the product's quality and originality.

- › **Value for Money:** Original McCormick parts are reliable and good value: they improve your tractor performance, maintain high productivity levels and preserve your tractor's value.

All McCormick spare parts rely on our extensive design and manufacturing expertise. Because when you choose McCormick, you are choosing quality without compromise.



POWER TECHNOLOGY, SINCE 1847

Cyrus Hall McCormick was born in Virginia, United States, in 1809. A keen inventor, he stunned the agricultural world with inventions that mechanised the farm work. In 1831 he invented the first mechanical reaper. In 1847 McCormick established a factory for the production of grain harvesters. In 1866 the company adopted the red colour that still identifies the brand worldwide. In 1871 McCormick manufactured more machines than any other company in the world: 250 reapers per day. The first tractor, the Mogul 8-16, was launched in 1906. In those years, the company opened up factories in Canada, Great Britain, Germany, France and Sweden.

In the following years, the company was purchased and sold several times. In 2000 McCormick was acquired by the Argo Group, which relaunched the brand under the name McCormick Tractors International Limited. Today, McCormick is a world leader in the tractor industry and its name stands for uncompromising technology and innovative design. Thanks to heavy investments in research and development, the new generation of McCormick tractors leads the market for performance and innovation. Farmers look for efficient, reliable and versatile solutions to maximise their productivity – and this is exactly what we are proud to offer our customers.

		X8.627 VT-DRIVE	X8.631 VT-DRIVE
ENGINE			
Rated power (ISO/TR 14396)	hp / kW	250 / 184	301 / 221
Max power (ISO/TR 14396)	hp / kW	273 / 201	313 / 230
Rated engine speed	rpm		2100
Engine speed at max power	rpm		1800
Max torque at 1400 rpm	Nm	1173	1282
Torque backup		40%	28%
Manufacturer		FPT	
Engine type - Installation		NEF 67 - iso-mounted engine on cast iron chassis	
Stage V / Tier 4 Final exhaust after-treatment system		HI-eSCR2	
Cylinders / Displacement / Valves		6 / 6.7 l / 24	
Air filter system		air filter with pre-cleaning stage and dust ejector	
Air intake system		eVGT electronic variable geometry turbocharger with intercooler	
Fuel injection system		electronically-controlled high pressure common rail injection system	
Maintenance		Best In Class system (BIC) - 1000-hour maintenance interval	
Cooling system		matrix radiator pack - coolers open out from a single latch	
Viscotronic fan		<ul style="list-style-type: none"> 	
CAPACITIES			
Fuel tank	l	550	
AdBlue / DEF tank	l	71	
Cooling system	l	30	
TRANSMISSION			
Type		VT-Drive - continuously variable transmission	
No. of stages		4	
Minimum speed - engine speed	m/h - rpm	40 - 2200	
Engine speed at 40 km/h	rpm	<ul style="list-style-type: none"> - 1300 	
Engine speed at 50 km/h	rpm	<ul style="list-style-type: none"> o - 1580 	
Transmission control		EasyPilot with multifunction armrest	
Forward/reverse shuttle		electrohydraulic with modulation control	
REAR PTO			
Type		electrohydraulic multidisc clutch with modulated engagement	
Speeds		540 E / 1000 / 1000 E	
Engine speed at rated PTO speed	rpm	1580 / 1943 / 1605	
Rotation - spline shaft type		clockwise (viewed from tractor rear) - <ul style="list-style-type: none"> • 1-3/8" PTO shaft with 6 splines / o 1-3/8" PTO shaft with 21 splines 	
FRONT AND REAR AXLES			
Front rigid axle		<ul style="list-style-type: none"> • - (EFFICIENT version) 	
Front suspended axle		<ul style="list-style-type: none"> • - parallelogram suspension system 	
Traction type		electrohydraulic 4WD	
Front differential lock		fully electrohydraulic	
Rear differential lock		fully electrohydraulic	
Rear axle - flanged type		<ul style="list-style-type: none"> • 	
Rear axle - bar axle type		o	
BRAKING SYSTEM			
Front braking system		<ul style="list-style-type: none"> • - oil-bath disc brakes 	
Rear braking system		6 oil-bath discs	
Trailer braking system		<ul style="list-style-type: none"> • - pneumatic brake with 2 or 2+2 lines with/without single-line hydraulic brake as per MR - 2-line hydraulic brake as per MR (40 km/h only) 	
Engine brake		<ul style="list-style-type: none"> • 	
HYDRAULIC SYSTEM			
Hydraulic piston pump with CCLS system - high flow rate		<ul style="list-style-type: none"> • - 212 l/min 	
Steering pump - flow rate		<ul style="list-style-type: none"> • - 115 l/min 	
Rear remote valves - type, flow rate, min - max		electrohydraulic, 140 l/min, 4 - 6	
Flow diverter with flow selector - section flow rate		o - 3 sections with dedicated push-pull connectors - 60 l/min per section	

Free-flow return		<ul style="list-style-type: none"> •
Power Beyond adaptor and free-flow return		o
Power Beyond with push-pull connectors and free-flow return		o
Mid-mounted remote valves - type, number, flow rate		<ul style="list-style-type: none"> • - 3 electrohydraulic remotes with multifunction joystick - 100 l/min
Hydraulic oil take out	l	70
REAR 3-POINT HITCH		
Electronically-controlled rear hitch		with lower link draft control, position control, mixed control, float position
Category - hitch type		<ul style="list-style-type: none"> • - III - quick-hitch ball ends - o - IV N - quick-hitch ball ends
Max lift capacity at the hooks - ram diameter	kg	12000 - 120 mm
FRONT 3-POINT HITCH		
Electronically-controlled front hitch		<ul style="list-style-type: none"> • - with position control
Category - coupler type		III N - ball ends with quick-hitch hooks
Lift capacity at the hooks (OECD at the hooks)	kg	5000
FRONT PTO		
Type		o - electrohydraulic multidisc clutch with modulated engagement
Speeds		1000
Engine speed at rated PTO speed	rpm	1920
Rotation - spline shaft type (North American version)		counter-clockwise (viewed from tractor front) - 1-3/8" PTO shaft with 21 splines
CAB		
Clever Cab - 4-post cab with McCormick mechanical suspension		o (EFFICIENT version)
Clever Cab - 4 -post with McCormick semi-active suspension system		<ul style="list-style-type: none"> • -electronically-controlled electrohydraulic semi-active cab suspension (PREMIUM version)
In-cab noise level		68
Automatic climate control		<ul style="list-style-type: none"> •
Deluxe air suspension seat		<ul style="list-style-type: none"> • - low-frequency air suspension, swivel and height adjustments, manual weight control, lumbar support and headrest
Super Deluxe air suspension seat with swivel headrest		o - Dynamic Damping System, backrest ventilation, alcantara upholstery, swivel and height adjustments, automatic weight control, lumbar support and swivel headrest
Trainer seat		<ul style="list-style-type: none"> •
EasyPilot with multifunction armrest		<ul style="list-style-type: none"> •
DSM Data Screen Manager		<ul style="list-style-type: none"> • - 12" touch screen monitor
MyFunctions		<ul style="list-style-type: none"> • - with DSM
MyLights		<ul style="list-style-type: none"> • - with DSM
MyHMF		<ul style="list-style-type: none"> • - with DSM
Sound system		Alpine touchscreen radio DAB Apple Car Play & Android Auto with 4 Alpine speakers, bluetooth, aux-in and integrated microphone
LED work lights		<ul style="list-style-type: none"> • - 20
LED Beacon lights		<ul style="list-style-type: none"> • - left and right side
ONBOARD TECHNOLOGY		
Front ISOBUS		o
Rear ISOBUS		<ul style="list-style-type: none"> •
PSM Precision Steering Management, rear ISObus & EazySteer - ready		<ul style="list-style-type: none"> •
PSM Precision Steering Management, rear ISObus & EazySteer		o - EGNOS full kit o RTK NTRIP full kit - AT Spare Parts
McCormick Fleet & Remote Diagnostics Management, Farm Management and Pro Pack		on selected markets <ul style="list-style-type: none"> • - 1 year o - 3 years o - 5 years
WEIGHTS AND DIMENSIONS		
Wheelbase	mm	3000
Max height over cab without beacon lights (with PSM satellite steering system)	mm	3354 (3445) - measured with tyres 650/65R34 - 900/60R42
Max height from top of cab to rear axle centre (with PSM satellite steering system)	mm	2400 (2491)
Max length with front weights - Max width	mm	6569 - 2930 measured with tyres 650/65R34 - 900/60R42
Steering radius	mm	5400 measured with tyres 650/60R34 - 710/70R42
Shipping weight - measured with average specs	kg	11000
Gross vehicle weight	kg	16000
Max front and rear tyre size - (Index Radius - IR)	mm	650/65R34 (IR 775) - 900/60R42 (IR 1025)
Front hitch weight	kg	o - 1400 o - 1800
Rear axle weights	kg	o - 300 x 2 o - 300 x 4

Key: • standard o option



Power Technology.

via G. Matteotti, 7 | 42042 Fabbro [RE] Italia | t. +39.0522.656.111 | f. +39.0522.656.476
webmaster@argotracors.com | www.argotracors.com



graphic design: **gruppo saldatori** | bzzbz@grupposaldatori.com

All data and illustrations provided in this brochure are for information purposes



6737480A1